

500-012 4 CHANNEL RF GENERATOR

500kHz, 100W Phased Array Driver

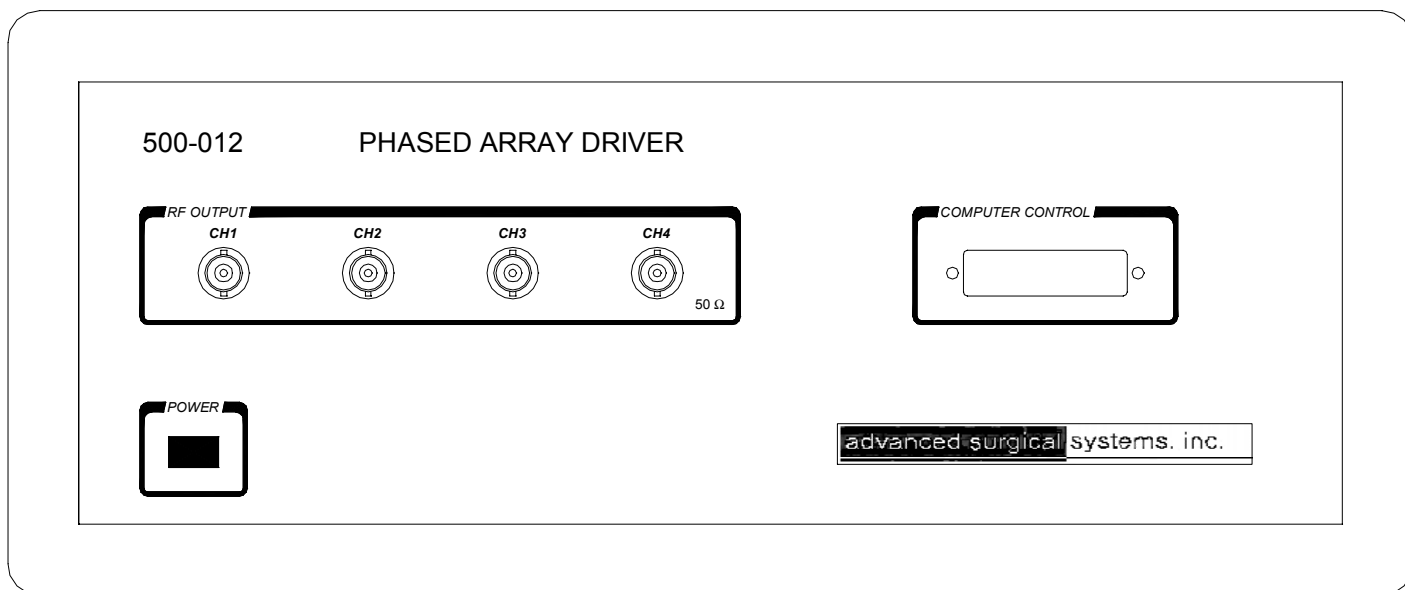

# Users Guide



# WARNING

---

**This device is not intended for use on human subjects.**

Advanced Surgical Systems, Inc. does not recommend nor authorize the use of the 500-012 RF Generator on human subjects. This device does not currently have the necessary regulatory approvals for patient use.

All information contained herein was deemed accurate at the time of writing. Advanced Surgical Systems, Inc. reserves the right to change and/or modify the specifications contained within.



# Limited Warranty

---

Advanced Surgical Systems, Inc. warrants the 500-012 RF Generator to be free from defects in materials and workmanship for a period of one (1) year from the date of shipment. If any such product proves defective during this warranty period, Advanced Surgical Systems, at its option, either will repair the defective product without charge for parts and labor, or will provide a replacement in exchange for the defective product.

In order to obtain service under this warranty, the Customer must notify Advanced Surgical Systems of the defect before the expiration of the warranty period and make suitable arrangements for the performance of service. The Customer shall be responsible for packaging and shipping the defective product to the service center designated by Advanced Surgical Systems, with shipping charges prepaid. Advanced Surgical Systems shall pay for the return of the product to Customer if the shipment is to a location within the United States. Customer shall be responsible for paying all shipping charges, duties, taxes, and any other charges for products returned to any other locations.

This warranty shall not apply to any defect, failure or damage caused by improper use of the device or improper or inadequate maintenance and care. Advanced Surgical Systems shall not be obligated to furnish service under this warranty to a) repair damage resulting from attempts by personnel other than Advanced Surgical Systems personnel to install, repair or service the product; b) to repair damage resulting from improper use or connection to incompatible equipment; or c) to service a product that has been modified or integrated with other products when the effect of such modification or integration increases the time or difficulty of servicing the product.



# Technical Support

---

Technical support is available at no charge throughout the life of the product.

Additionally, Advanced Surgical Systems is willing to work with its customers to make sure that the equipment is used to its maximum potential, whether this be regarding interfacing with the transducers, developing control software, or any other issues that may arise throughout the lifetime of the UDS system.



## **Postal address**

Advanced Surgical Systems, Inc.  
5030 East Calle Barril  
Tucson, Arizona 85718



## **Telephone**

(520) 529-1796



## **FAX**

(520) 529-5541



## **E- mail Address**

[support@advanced-surgical.com](mailto:support@advanced-surgical.com)



# Safety

---

## IEC Symbols



This symbol indicates “HAZARDOUS VOLTAGES MAY BE PRESENT”.



This symbol indicates “PLEASE REFER TO THE INSTRUCTION MANUAL FOR SPECIFIC WARNING OR CAUTION INFORMATION TO AVOID PERSONAL INJURY OR DAMAGE TO PRODUCT”.

## Safety Terms

**CAUTION:** Identifies conditions or practices that could result in damage to the equipment

**WARNING:** Identifies conditions or practices that could result in injury or loss of life

## Specific Precautions

### Power Source

The UDS system must be operated between 115-230VAC at 50/60Hz.

### Grounding the UDS system

The UDS system is grounded through the power cord. Use the power cord supplied with the system.

### Fuse

To avoid fire hazard, use a 50x20mm fuse rated for 7A @ 115VAC or 3.5A @ 230VAC.

### Covers

Covers should not be removed due to risk of electrical shock.

<b>1. QUICK START</b> .....	<b>1-1</b>
System Overview.....	1-1
Setup .....	1-1
<b>2. SYSTEM OVERVIEW</b> .....	<b>2-1</b>
Introduction.....	2-1
Safety.....	2-1
Basic Operations .....	2-1
<b>3. INTERFACE SOFTWARE</b> .....	<b>3-2</b>
Introduction.....	3-2
Programming Frequency .....	3-3
Channel Power .....	3-3
Power Feedback Mode:.....	3-3
Voltage Feedback Mode: .....	3-4
Channel Phase.....	3-4
Channel Enable .....	3-4
Measured Power .....	3-5
Lock LEDs.....	3-5
Power Feedback.....	3-6
Phase Feedback.....	3-6
Setting the Parallel Port Address .....	3-7
External Enable.....	3-7
Status Bar .....	3-7
<b>4. THEORY OF OPERATION</b> .....	<b>4-1</b>
Amplifier Design .....	4-1
Phase Control .....	4-2
<b>5. APPENDIX A</b> .....	<b>5-2</b>

**Specifications.....5-2**



## 1. Quick Start

### System Overview

The 500-012 RF Generator features four independent outputs capable of generating RF signals in the 500kHz frequency range with up to 100W per channel.

### Setup

1. Carefully unpack the amplifier from the shipping crate. Save the crate. The amplifier should always be shipped in the supplied carton. Be sure that the following items are included with the system:
  - Four-channel amplifier system
  - AC power cord
  - Interface software
  - Parallel port interface cable
2. Inspect the system for any damage that may have occurred during shipping.
3. Connect interface cable between the computer's parallel port and the interface connector on the generator.
4. Install Interface software.
5. Make sure the AC POWER switch on the front panel is in the off position (switch should be out). Connect the AC power cord to the rear panel of the amplifier.
6. Connect a load to the amplifier.



**The amplifier is designed to drive 50Ω loads. While some mismatch is acceptable, it is possible to damage the system by attempting to drive widely mismatched loads. Also, do not operate the amplifier without a load connected.**

7. Turn on the RF Generator by pressing the POWER switch in.
8. Start the Interface software.

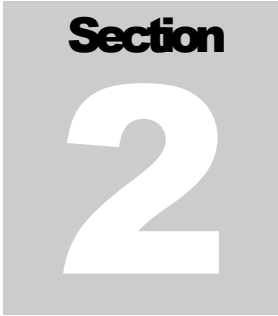

A gray square graphic containing the word "Section" in a bold, black, sans-serif font at the top, and a large, white, sans-serif number "2" in the center.

## 2. System Overview

### Introduction

The 500-012 RF GENERATOR is designed to generate an RF signal necessary to drive ultrasound transducers in the 500-600kHz frequency range, supplying up to 100W per channel.

All four channels of the system may be set up and operated independently. In addition, under software control, all channels may be enabled or disabled simultaneously, each channel retaining its own settings, with the outputs gated on or off together.

The 500-012 RF GENERATOR allows the user to independently select a desired output power for each channel. All power levels are displayed in watts. The standard display also shows the phase setting in of each channel.

### Safety

The network of distributed control allows for a much higher degree of safety than would otherwise be possible in a system with a large number of channels. As the microcontrollers are directly integrated into the feedback network of the amplifiers, forward and reflected power can be measured and compared to preset limits hundreds of times each second. Should the measured power deviate beyond the preset limits, the microcontroller can either immediately shut down the amplifier channel automatically or simply prompt the user for intervention. As each channel is independently controlled, all channels need not have the same limits nor respond to over-limit conditions with the same action.

### Basic Operations

To set up a desired frequency and power output, the following steps must be performed:

1. On AC power up, the system will boot up and default to the local mode
2. Set the desired power for the channel
3. Set the desired phase for the channel.
4. Enable the channel by clicking on the check box next to the power.
5. Press the Enable button to begin power delivery.

## Section

## 3

### 3. Interface Software

#### Introduction

The 500-012 4 channel Phased Array RF Generator is controlled by a host PC running Microsoft Windows. A 25-pin “D” (parallel printer cable) connects between the PC and the RF Generator. The Phased Array Interface software controls all aspects of the RF Generator’s output.

The general layout of the Phased Array Interface can be seen in Figure 1. The output channels are arranged in rows, and the controls in columns. The first column is Channel Enable check boxes, followed by the Power and Phase programming text boxes.

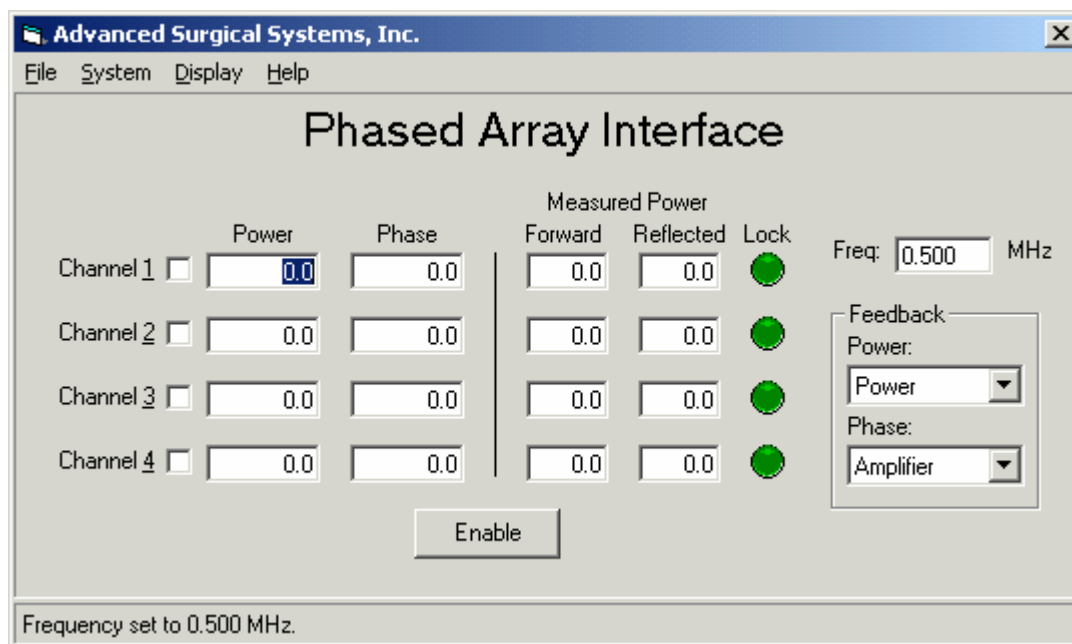

Figure 1. General Screen Layout.

The next two columns display the measured forward and reflected power of any channels that are enabled. The LEDs indicate a loss of phase lock, and whether an output is producing RF power.

The operating frequency of the generator is controlled in the Freq text box. The feedback controls allow the selection of different feedback sources for the power and phase.

**Programming Frequency**

The output frequency is programmed using the Freq text box (Figure 2). The frequency must be entered in MHz. If a frequency value is entered that is outside of the range of the generator, a pop up box will appear warning of the error. Once OK is pressed on the error pop up, the invalid frequency value will be ignored, and the existing frequency will appear in the Freq text box.

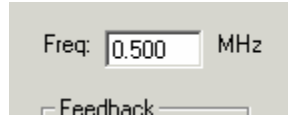

Figure 2. Freq Text Box.

When the frequency is changed, the following occurs:

- 6. The output is disabled.
- 7. The frequency is reprogrammed.
- 8. The programmed phase values are recalculated and reprogrammed to the generator.
- 9. The output is re-enabled.

The output is disabled to prevent a loss of phase lock when phase feedback is enabled.

**Channel Power**

**Power Feedback Mode:**

The output power of each of the generator channels is controlled by the Power text box column (Figure 3). The power is entered in the text box in Watts. If an invalid power value is entered, an error pop up window will indicate that an invalid value was entered, and the invalid value will be ignored.

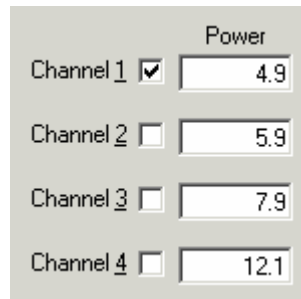

Figure 3. Channel Power Text Box.

When a valid power is entered, the closest possible value that the generator can produce is calculated and this value replaces the desired value entered by the user. In Figure 3, 5W was entered into the Power text box for Channel 1 and the nearest producible value, 4.9W was substituted.

It is also possible to enter a binary value that represents the actual 8-bit DAC code by prefacing the value with a “#” symbol. E.g. “#95” will program the generator DAC to code

95. Valid DAC values are #0 - #255. Since this value is not calibrated in Watts, this mode of programming is not very useful.

*NOTE: OUTPUT POWER IS NOT A LINEAR FUNCTION OF THE DAC CODES!*

**Voltage Feedback Mode:**

In Voltage Feedback Mode, the power calibration is no longer valid. Data can be entered into this field in either Watts or as a binary value. Care should be taken when doing this so as to not deliver too much RF power to the load as damage to the generator or load might result.

	<b>Do not change the Power Feedback source while the output is enabled. There will be a substantial change in output power when this occurs, and a large increase in output power is possible.</b>
-----------------------------------------------------------------------------------	----------------------------------------------------------------------------------------------------------------------------------------------------------------------------------------------------

**Channel Phase**

The relative phase of each of the generators is controlled by the Phase text box column (Figure 4). The phase value is entered in degrees. Any value can be entered (both positive and negative) and the nearest valid value is calculated between 0 and 360°. Because of the method used to produce the phase shifts, the actual phase for a given channel will change if the frequency is changed.

	Power	Phase
Channel 1 <input checked="" type="checkbox"/>	4.9	0.0
Channel 2 <input type="checkbox"/>	5.9	180.0
Channel 3 <input type="checkbox"/>	7.9	90.0
Channel 4 <input type="checkbox"/>	12.1	45.0

Figure 4. Phase Text Box Column.

**Channel Enable**

The Channel Enable check boxes, show in Figure 5 select which individual channels will produce power when the Enable Button is pressed. If the Enable Button is already active, clicking on a Channel Enable checkbox will cause the selected channel to begin producing power immediately.

	Power	Phase
Channel 1 <input checked="" type="checkbox"/>	4.9	0.0
Channel 2 <input type="checkbox"/>	5.9	180.0
Channel 3 <input type="checkbox"/>	7.9	90.0
Channel 4 <input type="checkbox"/>	12.1	45.0

Figure 5. Channel Enable Checkbox Column.

If an error occurs that causes a particular channel to be turned off, the affected channel will automatically have its Channel Enable checkbox deselected. Additionally, the lock LED will indicate there was a problem by turning red.

**Measured Power**

The Measured Power text boxes are a display only control (Figure 6). When the generator is enabled, the measured forward and reflected powers are displayed in Watts for all channels that are enabled. The displayed power is an averaged measure of the respective powers.

Measured Power	
Forward	Reflected
4.94	0.0
0.0	0.0
0.0	0.0
0.0	0.0

Figure 6. Measured Power.

If the measured reflected power exceeds 10W, or the forward power exceeds 110% of the maximum power, the channel will automatically be disabled.

**Lock LEDs**

The LOCK LEDs indicate the status of each of the channels (Figure 7). If no error exists for a particular channel, the LED will be green. If the channel is producing power (the channel is enabled, and the Enable Button is active), the LED will be bright green. When an error occurs, as shown in Figure 8, the Lock LED will turn red.



Figure 7. Lock LEDs.



Figure 8. Lock LEDs during error condition.

If the Lock LED flashes red, the channel has lost phase lock and was disabled. All other errors simply cause the LED to turn dark red when the error causes the channel to disable.

### Power Feedback

The RF generator has two modes for controlling the output power: Power Feedback and Voltage Feedback. Power feedback is the default, and most commonly used mode. Power feedback allows the user to program the Forward RF power in Watts and the generator automatically maintains that level, even over changes in load and frequency. Voltage Feedback is a special mode, usually used in conjunction with the External Enable input to allow very short RF pulses to be produced.

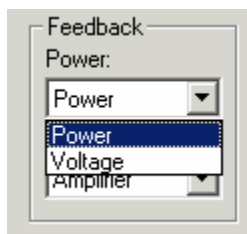

Figure 9. Power Feedback Selection Control.

In voltage feedback mode, the output voltage of an intermediate stage of the RF generator is kept at a constant value which allows the RF power to already be at the desired level when the generator is enabled. When Power Feedback is in use, this voltage starts at or near 0V and ramps up to the desired level in 1 - 5ms. Voltage Feedback mode eliminates this delay by maintaining the intermediate stage voltage.

Unfortunately, there is no static correlation between the intermediate voltage and the output power. It is very dependant on both frequency and load impedance. At one frequency, a particular power setting in Voltage Feedback mode can produce 2 – 3 times the expected power during Power Feedback. It is very important not to change modes while the output power is enabled unless the output power level has already been verified under actual operating conditions.



**Do not change the Power Feedback source while the output is enabled. There will be a substantial change in output power when this occurs, and a large increase in output power is possible.**

### Phase Feedback

The Phase Feedback control selects the source for the phase feedback circuitry (Figure 10). The three choices are: Amplifier, Backplane and Off. For this instrument, Backplane and Amplifier are the same point – the output of the amplifier. The phase feedback circuitry senses the phase of the output signal and synchronizes it with the phase reference for that channel. This compensates for any phase shifts that may occur in the RF section of the generator.

A Phase Lock error occurs when the phase compensation circuitry loses “Lock” with the reference signal. This condition forces the shutdown of the affected channel since a loss of phase lock can result in an unknown output frequency. This condition sometimes occurs when there is a large step in output power and the load changes rapidly as a result.

The Off selection turns the phase sensing off. This prevents the correction of phase errors in the RF section, so it is not a recommended operating mode, but it is useful for troubleshooting phase lock errors.

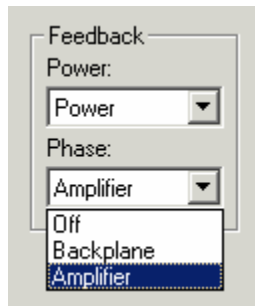

Figure 10. Phase Feedback Selection Control.

### Setting the Parallel Port Address

The default parallel port address is &H378 (&H signifies a hexadecimal number), which is 888 in decimal. This is the standard parallel port address for LPT1. This address can be changed by selecting the System->Parallel Port menu item. Simply enter the address of the desired parallel port into the dialog box.

Alternatively, the parallel port address can be changed in the system registry. *Modifying the system registry can cause unstable operation of your computer, so please be careful.*

The parallel port address can be found at the following key:

```
HKEY_CURRENT_USER\Software\VB and VBA Program Settings\Phased Array  
Test Interface\Settings\PortAddress
```

### External Enable

The External Enable input can be found at the rear of the unit. This input allows the RF generator to be pulsed or controlled by an external TTL level control. Connect the external controller to the EXT Enable input, select the System->Ext Enable menu item, program the generator to operate in the desired mode: set the power, phase, select which channels are enabled and press the Enable Button. As long as the EXT Enable input is held low, no RF power is generated, but when the signal is high, RF power is produced.

If the System->Ext Enable menu item is not checked, all enabled channels will be disabled and an Internal Temperature error will be erroneously reported in the Status Bar. The generator is unable to distinguish between an Internal Temperature error and the EXT Enable line being held low.

### Status Bar

The Status Bar is located along the bottom part of the main form of the program. This is where many events are noted. If an error occurs that results in the disabling of a channel, this error will be listed here. Also, there is the occasional communication error that may be reported. These are typically of little importance and simply represent a communications glitch caused by a timing error in Windows.



## 4. Theory of Operation

### Amplifier Design

The amplifier used in the 500-012 RF Generator is a highly efficient class D/E switching amplifier designed specifically for driving ultrasonic transducers. The amplifier topology used provides excellent efficiency but is limited to a narrow output bandwidth because of its resonant characteristics. Since the amplifier is very efficient, it can be compact, demanding minimal cooling requirements.

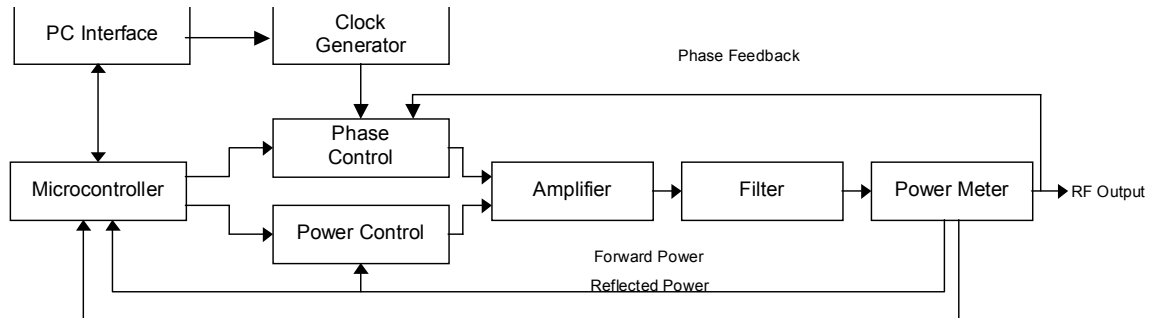

Figure 11. Block diagram of amplifier.

The amplifier has control of the output power and the operating frequency. A microcontroller is used to interface with an external computer and to monitor the operation of the amplifier. Commands sent by the interface computer are interpreted by the microcontroller and proper action is taken based on these commands. The microcontroller continuously monitors the forward and reflected power and the temperature of the amplifier itself (many of these terms will be explained later).

To overcome this problem, Advanced Surgical Systems has developed a novel power leveling scheme that senses the forward power delivered by the amplifier and automatically adjusts the output amplitude to compensate for any changes in the load impedance. The forward power is defined here as the amount of power that the amplifier sends to the load. If there is a perfect match between the output of the amplifier and the load (i.e. the load is real with a magnitude of  $50\Omega$ ), then all of the available power is delivered to the load. If there is any mismatch in impedance, a certain amount of power is reflected back to the amplifier. The amount of power dissipated in the load (forward power – reflected power) is referred to here as the transmitted power.

While both the forward power and reflected power are measured and monitored by the amplifier, only the forward power is used in the feedback loop. This is done to avoid problems

that could result from fault conditions in the transducer or associated transmission line. If the transmitted power was regulated, and the load was disconnected, or some other fault occurred, the amplifier output would immediately increase to maximum, creating a very unsafe situation.

**Phase Control**

Accurate phase control is very important when driving ultrasonic transducers, allowing each transducer to be operated at maximum efficiency, repeatable and reliably. The frequency is generated using a direct digital synthesizer (DDS). This clock signal is distributed to all channels in a phase coherent manner.

**5. Appendix A**

**Specifications**

Parameter	Value
<b>Generator</b>	
Number of Channels	4
Frequency Range	0.500 – 0.600 MHz
Frequency Resolution	1 kHz
Max. Output Power/Channel	100 Watts
Max. Output Power Total	400 Watts
Load Impedance	50 ohms
Phase Control Resolution	< 5°
Power Control Resolution	8 bits
<b>RF Power Measurement</b>	
Accuracy	±3%, ±0.6Watts
Resolution	12 bits
<b>Input Power</b>	
115-230VAC 7-3.5A 50/60Hz.	

Part No. 800-003  
Rev. A

© 2002 Advanced Surgical Systems, Inc.